



STATION TIME WHITE LED

P/N 069-2650-1-0

- Utilizes LED Technology for:
 - Long Life, Reduced Maintenance Costs.
 - Low Power Consumption.
- Water Resistant Aluminum Housing Compatible with TWINCO's LED Speed Sign
- Operates from 12VAC/DC, 25/60Hz
- 5-1/4" Diameter Clear Lens meets AAR Standards
- Provided with Rear Mounting Bracket for 3" Diameter Pole
- Other Custom Arrangements Available, Consult Factory



Certificate # 2380/00

PDS 2650-01 A

1 of 2

TWINCO MFG. CO., INC.

30 Commerce Dr., Hauppauge, NY 11788-3904

Ph 800-854-2338

Fx 631-231-0314

<http://www.twincomfg.com>

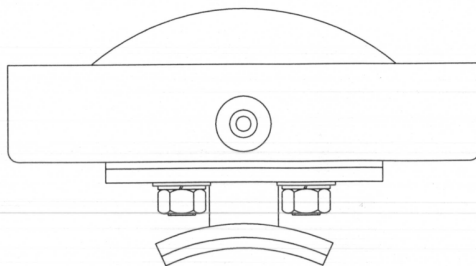
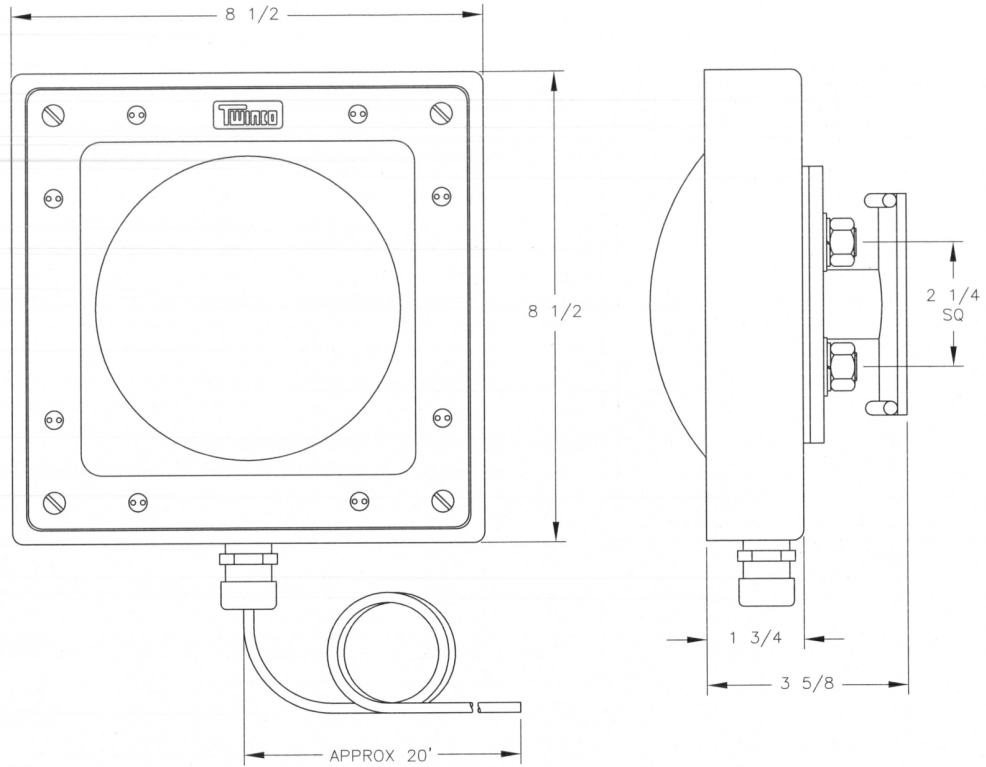

General Specifications

Weight	10 lbs
Power Consumption	5 watts at 12V